

外形尺寸 / Outer dimensions

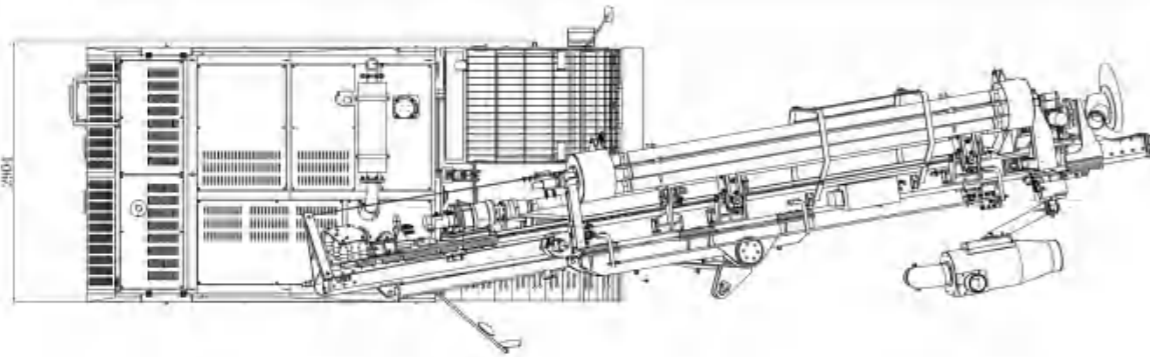

打孔范围 / Drilling range

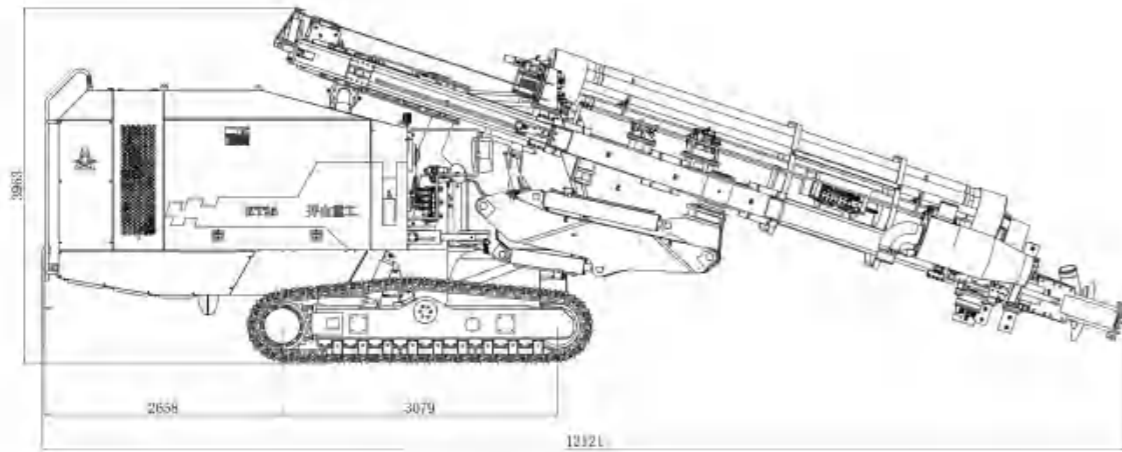
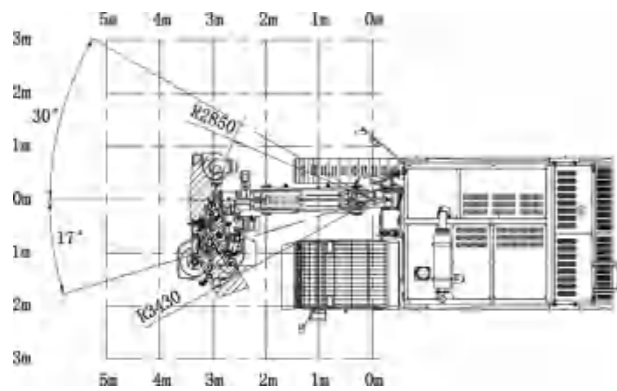

滑架倾斜角 /

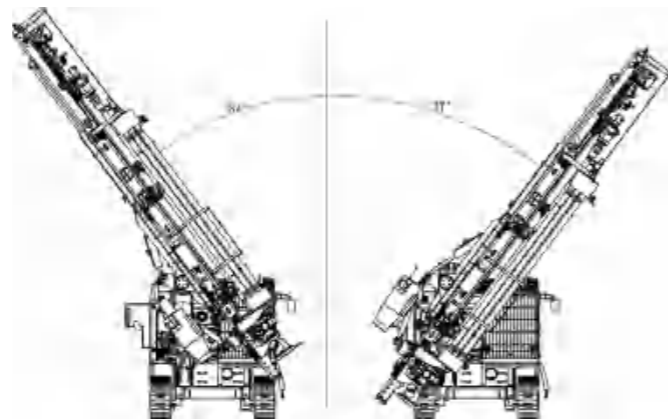

 **浙江开山重工股份有限公司**  
ZHEJIANG KAISHAN HEAVY INDUSTRY CO.,LTD.

地址：浙江省衢州市经济开发区凯旋南路10号  
销售热线：400 870 0207  
服务中心：400 826 6158  
邮箱：kszhgy@kaishangroup.com  
http://www.zjkszg.com  
http://www.kaishangroup.com

Add: No.10 kaixuan Street(S),Quzhou,zhejiang.China  
Sales phone: 400 870 0207  
Service phone: 400 826 6158  
E-mail:kszhgy@kaishangroup.com  
http://www.zjkszg.com  
http://www.kaishangroup.com

关注微信号  
了解更多



开山集团



开山重工



# KT25型一体式露天潜孔钻车

## KT25 Integrated Surface DTH Drilling Rig



品质开山 行业典范

# KT25型一体式露天潜孔钻车

## KT25 Integrated Surface DTH Drilling Rig

KT25型一体式潜孔钻车可钻凿垂直、倾斜和水平孔，主要用于大型露天矿山和石方工程钻凿爆破孔和预裂孔等。

KT25 integrated surface DTH drilling rig can drilling vertical, inclined and horizontal holes, mainly used for open-pit mine, stonework blast holes and pre-splitting holes.

以康明斯柴油机为单一动力，通过两端输出的方式同时带动螺杆压缩系统和液压传动系统；

It is driven by the Cummins diesel engine and the two-terminal output can drive the screw compression system and hydraulic transmission system.

钻车配有自动接卸杆系统、钻杆浮动接头模块、钻杆润滑模块，防卡钻系统、液压干式集尘系统、冷暖空调驾驶室、钻孔角度和深度指示功能等。

The drill rig is equipped with the automatic rod handling system, drill pipe floating joint module, drill pipe lubrication module, drill pipe sticking prevention system, hydraulic dry dust collection system, air conditioning cab, optional drilling angle and depth indication function, etc.

钻车具有整体性好、自动化程度高、凿岩效果好、环保节能、操作方便、机动灵活、行驶安全等特点。

The drill rig is characterized by excellent integrity, high automation, efficient drilling, environment-friendliness, energy conservation, simple operation, flexibility and travelling safety, etc.



### 技术参数 Technical Parameters

凿岩硬度 /Drilling hardness	f=6-20
钻孔直径 /Drilling diameter	152-203 mm
经济凿孔深度(自动接杆深度) Depth of economical drilling (depth of automatic extension rod)	35 / 36 m
行走速度 /Travelling speed	3.0 km/h
爬坡能力 /Climbing capacity	25°
离地间隙 /Ground clearance	410 mm
整机功率 /Power of complete machine	372 kW
柴油机 /Diesel engine	康明斯QSZ13-500-30 Cummins QSZ13-500-30
螺杆机 /Screw compressor	两级压缩31 m³/min / 25bar Two stage compression 31 m³/min / 25bar
外形尺寸(长×宽×高) /Outer dimensions (L×W×H)	12100×2900×3850 mm
重量 /Weight	28100 kg
回转器转速 /Revolving speed of gyrotor	0-100 / 0-150 r/min
回转扭矩 /Rotary torque	6100 N·m
最大推拉力 /Maximum Feed force	65 KN
推进方式 /Method of propulsion	马达+滚子链 /Motor+roller chain
滑架俯仰角度 /Tilt angle of beam	133°
滑架摆角 /Swing angle of carriage	向右37°向左37°/Right 37°, left 37°
钻臂摆角 /Swing angle of drill boom	向右30°向左17°/Right 30°, left 17°
钻臂举升角度 /Lifting angle of drill boom	向上49°向下13°/Up 49°, down 13°
车架调平角度 /Leveling angle of frame	向上10°向下10°/Up 10°, down 10°
补偿长度 /Compensation length	1800 mm
推进行程 /Feed stroke	5700 / 6700 mm
冲击器 /DTH hammer	吋、6吋 / 5", 6"
钻杆(φ直径×钻杆长度) /Drilling rod (φ× length of drilling rod)	Φ102/Φ114/Φ127×5000 mm or Φ102/Φ114/Φ127×6000 mm
容杆数量 /Number of rods	6+1 / 5+1
除尘方式 /Method of dust removal	干式(液压驱动旋风层流式) /湿式(可选) Dry (hydraulic cyclonic laminar flow) /wet (optional)
接杆方式 /Method of extension rod	自动接卸杆 Automatic unloading rod
自动防卡方式 /Method of automatic anti-jamming	电液控制防卡 Electro-hydraulic control anti-sticking
钻杆润滑方式 /Method of drilling rod lubrication	自动喷油润滑 Automatic oil injection and lubrication
钻杆螺纹保护 /Protection of thread of drilling rod	配有浮动接头保护钻杆螺纹 Equipped with the floating joint to protect the thread of drilling rod
钻进显示 /Drilling display	钻孔角度和钻孔深度实时显示 Real-time display of drilling angle and depth