

外形尺寸 / Dimensions

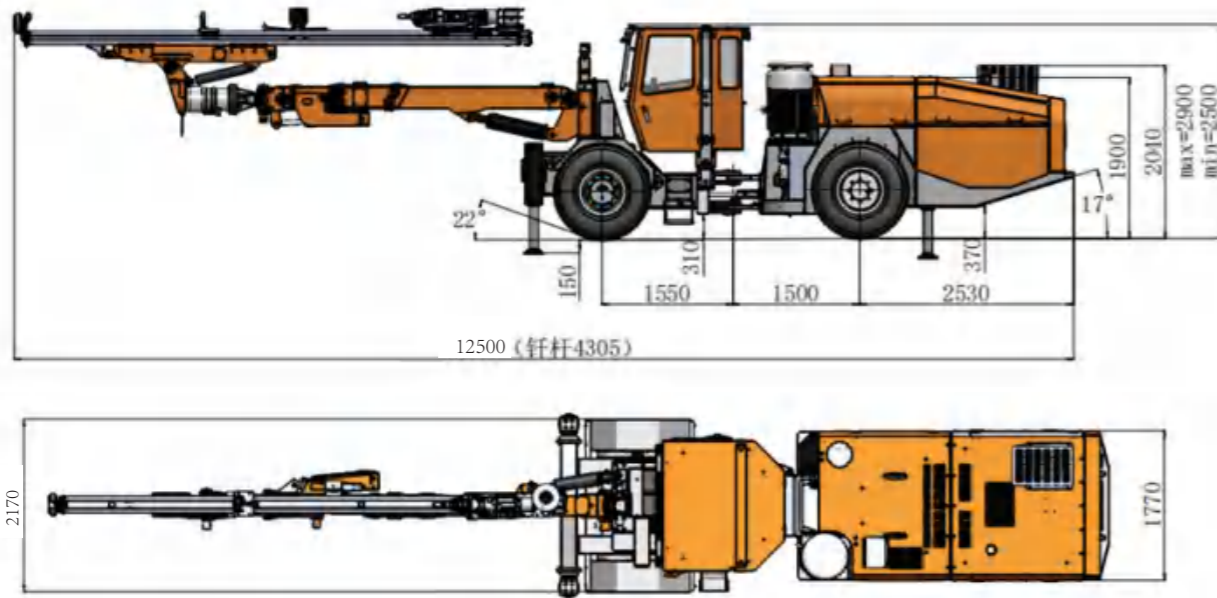

转弯示意 / Turning Diagram

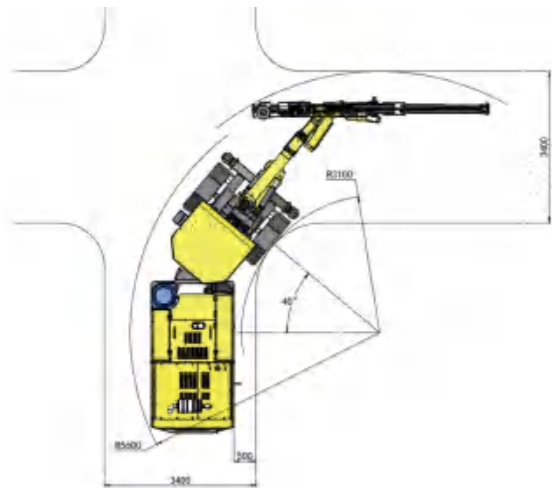

断面示意 / Coverage area

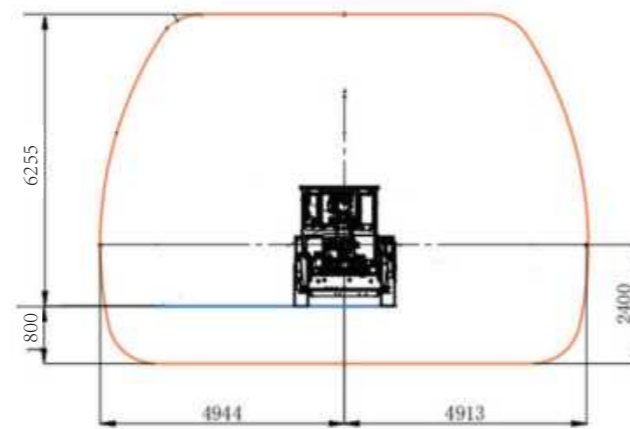

KJ311i型智能掘进钻车 (地下凿岩机器人)

KJ311i Intelligent Tunneling Drilling Rig
(Rock-drilling Robot Underground)



创造智能台车无人化新标准



地址: 浙江省衢州市经济开发区凯旋南路10号
 销售热线: 400 870 0207
 服务中心: 400 826 6158
 邮箱: kszghy@kaishangroup.com
 http://www.zjkszg.com
 http://www.kaishangroup.com

Add: No.10 kaixuan Street(S),Quzhou,zhejiang.China
 Sales phone: 400 870 0207
 Service phone: 400 826 6158
 E-mail:kszghy@kaishangroup.com
 http:// www.zjkszg.com
 http://www.kaishangroup.com

关注微信号
了解更多



开山集团



开山重工

KJ311i型智能掘进钻车 (地下凿岩机器人)

KJ311i Intelligent tunneling drilling rig (rock-drilling robot underground)

KJ311i型智能掘进钻车（地下凿岩机器人）是一款智能化巷道掘进设备，适用于3.5m×3.5m-9m×5.8m断面的硬岩矿山自动化掘进作业。

KJ311i intelligent drilling rig (rock-drilling robot underground) is an intelligent roadway tunneling equipment, suitable for the drilling of hard rock mine whose section falls in the range of 3.5m×3.5m-9m×5.8m.

● 远程控制系统

在巷道网络条件满足的矿山，可联网地面控制室，实现远程操作，一人可操作多机，减少甚至取消钻孔现场作业人员。

● Remote control system

In mines where the roadway network conditions are met, the ground control room can be networked to achieve remote operation, and one person can operate multiple machines, reducing or even canceling the drilling site operator.

● 辅助停机系统

配备激光测距仪，引导钻车在完全覆盖工作面钻孔范围的合理区域内停车后，自动展开支腿、调整钻车水平。

● Auxiliary shutdown system

It is equipped with laser rangefinder to guide the drilling rig to stop in a reasonable area covering the drilling range of the working face, and then automatically deploy the legs and adjust the level of the drilling car.

● 模拟计算系统

扫描工作面，通过系统处理后，实现工作面3D图形的构建和显示，结合矿山布孔方案，计算孔位合理性，并确定最佳钻孔顺序。

● Analog computing system

After scanning the working face and processing by the system, the construction and display of the 3D graphics of the working face are realized. The rationality of the hole position is calculated according to the mine hole layout scheme, and the optimal drilling sequence is determined.

● 孔位定位系统

自动驱动钻臂和推进梁至钻孔顺序里的目标位置，完成孔位定位。

● Hole positioning system

The drill boom and beam are automatically driven to the target position in the drilling sequence to complete the hole positioning.

● 自动钻孔系统

自动完成开孔、钻孔、钻孔参数调节、防卡钻调节、洗孔、退出等全部钻孔动作，直至完成所钻孔任务。

● Automatic drilling system

Automatically complete all drilling operations, such as opening, drilling, drilling parameter adjustment, anti-stuck drilling adjustment, hole washing, and exit until the drilling task is completed.

● 数据采集和分析处理模块

采集钻孔过程数据，为改善钻孔工艺提供依据，让设备越用越高效。

● Data acquisition and analysis processing module

The drilling process data is collected to provide a basis for improving the drilling process and make the equipment more and more efficient.



外形尺寸与重量 / Dimensions and weight

长度 / Length	12500mm
宽度 / Width	2170mm
高度 / Height	2500/2900 mm
重量 / Weight	约16050kg/Apr. 16050kg
行驶速度(水平) Tramming speed on flat ground	10km/h
最大爬坡能力 Maximum climbing capacity	25%(14°)

安全防护 / Safety protection

噪音水平 / Noise level	<100dB(A)
可升降安全顶棚 Lifting safety roof	FOPS & ROPS认证

风水路系统 / Air & water system

空压机 /Air compressor	DLGF0.7/8-5.5(B)
排量 /Capacity of air compressor	0.7m³/min
压力 /Pressure	6-8bar
钎尾润滑装置 Device of shank lubrication	电磁脉冲润滑泵 Electronic pulse lubrication pump
润滑油气量 Air consumption of lubrication	0.3m³/min
润滑油油量 Oil Consumption of lubrication	180-250g/h
水泵功率 Power of water pump	1.5kW 4kW
水泵排量 Capacity of water pump	3m³/h 5.8m³/h

底盘 / Chassis

柴油机 Diesel engine	Cummins B3.9CS4-130C 96KW/2500rpm
传动系统 Drive system	四轮驱动闭式行走系统 Closed hydraulic system for four-wheel driving
摆动角 Swing angle	后桥摆动±10° Swing of rear axle: ±10°
转向机构 Steering mechanism	±40°铰接转向 Articulated steering: ±40°
行车制动 Travelling braking	双回路液压制动器 Two-circuit hydraulic brake
驻车制动 Parking braking	减速器多盘湿式制动器 Wet multidisc brake of reducer
燃油箱 Fuel tank	60L

钻进系统 / Drilling system

凿岩机/Rock drill	HC50	18U	HCL95LMH/22U
钎尾尺寸/Rod size	R38 / T38	T38	R38 / T38
冲击功率/Impact power	13KW	18KW	21KW / 22KW
频率/Impact Frequency	62Hz	57Hz	62Hz / 53Hz
孔径/Hole diameter	Φ32-76mm	Φ42-89mm	Φ42-102mm
推进梁翻转/Beam rotation		360°	
推进梁补偿行程/Feed extension		1600mm	
钻臂型号/Model of drill boom		K 36	
钻臂形式/Form of drill boom		自动持平/Self-leveling	
钻臂伸缩/Boom extension		1800mm	