

外形尺寸 / Dimensions

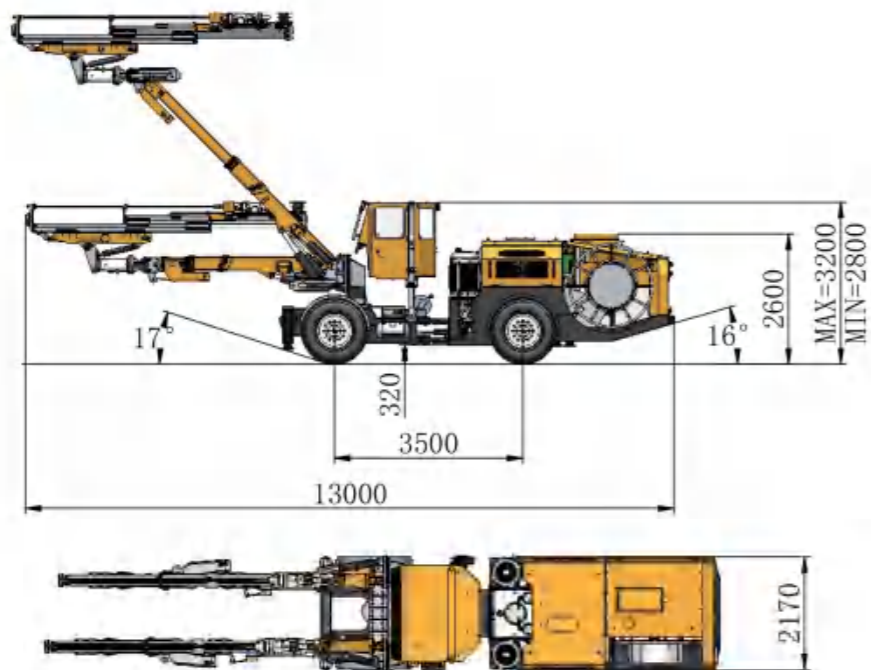

转弯示意 / Turning Diagram

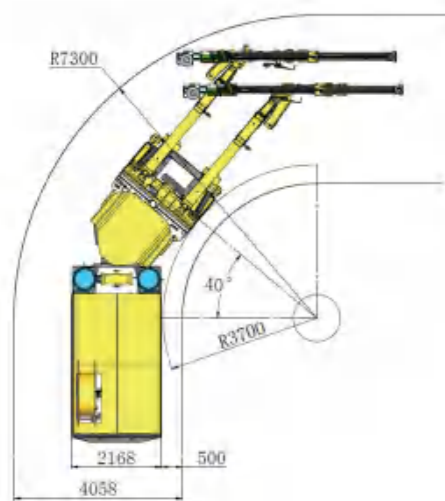

断面示意 / Coverage area

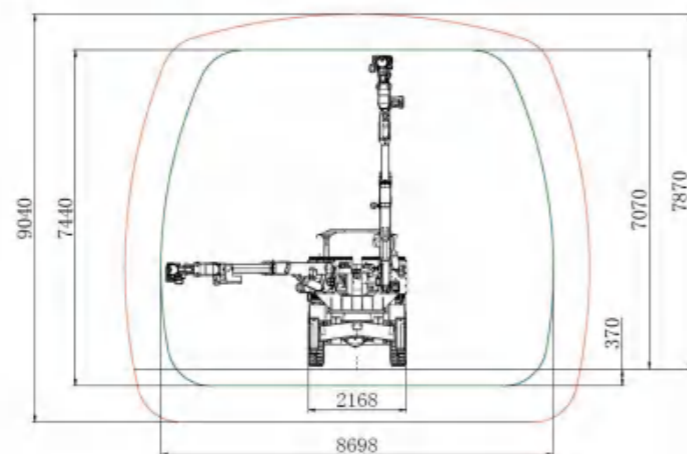

# KJ421型全液压掘进钻车

## KJ421 Hydraulic Tunnelling Drilling Rig



地址：浙江省衢州市经济开发区凯旋南路10号  
 销售热线：400 870 0207  
 服务中心：400 826 6158  
 邮箱：kszhgy@kaishangroup.com  
<http://www.zjkszg.com>  
<http://www.kaishangroup.com>

Add: No.10 kaixuan Street(S),Quzhou,zhejiang.China  
 Sales phone: 400 870 0207  
 Service phone: 400 826 6158  
 E-mail:kszhgy@kaishangroup.com  
<http://www.zjkszg.com>  
<http://www.kaishangroup.com>

关注微信号  
 了解更多



开山集团



开山重工

品质开山 行业典范

# KJ421型 全液压掘进钻车

## KJ421 Hydraulic Tunnelling Drilling Rig

KJ421型全液压掘进钻车适用于16-68m<sup>2</sup>断面的隧道掘进作业，可以钻凿垂直、倾斜和水平爆破孔和锚杆孔。

KJ421 hydraulic tunnelling drilling rig is suitably qualified for the drilling of tunnels whose section falls in the range of 16-68 square meters, capable of drilling the blast hole and rock bolting in a vertical, inclined and horizontal way.



- 钻车采用对称布置的两套直角坐标万向钻臂，没有作业盲区。推进梁360度翻转和自动持平便于快速方便地实现钻孔定位，同时还可用于侧向开石门和锚杆钻孔作业；

- The drilling rig is fitted with the flexible boom in two symmetric rectangular coordinates, without any operation blind spot. 360° rotation and self-leveling beam make drill positioning easy; it can also be used for the drilling of lateral cross-cut and rock bolting;

- 钻车布置确保司机视野良好；布置平衡，强劲有力的四轮驱动铰接底盘确保在狭窄巷道中能够灵活，快速，安全行驶；

- The drill rig provides a good view for the operator; balanced layout and the articulated chassis of four-wheel drive ensure the flexible, fast and safe driving in the narrow tunnel;

- 高频冲击凿岩机采用梯级活塞优化了冲击波传递效率，提高钻进速度，降低钎具消耗并提高设备的完好率；

- The stepped piston is used for the high-frequency impacting rock drill and this can improve the transmission efficiency of impact wave and drilling speed and reduce the consumption of drilling tools and make it in good condition;

- 宽敞的作业空间和一系列自动功能有助于司机集中精力安全、快速、准确地钻进；

- Considerable space and automatic functions enable the driver to concentrate on drilling in a safe, fast and accurate manner;

- 各个维修保养部位均受到良好的保护，同时又易于维护保养；

- All the relevant parts are kept in good protection, meanwhile easy to maintain.

### 外形尺寸与重量 / Dimensions and weight

长度 / Length	13000 mm
宽度 / Width	2200 mm
高度 / Height	2400/3100 mm
重量 / Weight	约22000 kg /Appr. 22000kg
行驶速度(水平) Tramming speed on flat ground	10km/h
最大爬坡能力 Maximum climbing capacity	25%( 14°)

### 安全防护 / Safety protection

噪音水平 / Noise level	<100dB(A)
可升降安全顶棚 Lifting safety roof	FOPS & ROPS认证

### 风水路系统 / Air & water system

空压机 /Air compressor	DLGF 1.5/8-11(B)
排量 /Capacity of air compressor	1.55m <sup>3</sup> /min
压力 /Pressure	8bar
钎尾润滑装置 Device of shank lubrication	电磁脉冲润滑泵 Electronic pulse lubrication pump
润滑耗气量 Air consumption of lubrication	2x0.3m <sup>3</sup> /min
润滑耗油量 Oil Consumption of lubrication	2x180-250g/h
水泵功率 Power of water pump	7.5kW
水泵排量 Capacity of water pump	10m <sup>3</sup> /h

### 底盘 / Chassis

柴油机 Diesel engine	Cummins B3.9CS4-130C 96KW/2500rpm
传动系统 Drive system	液力变矩器+变速箱 Hydraulic torque converter +gearbox
行车制动 Travelling braking	桥内湿式制动器 Wet bridge brake
驻车制动 Parking braking	机械制动器 Mechanical brake
燃油箱 Fuel tank	120L

### 钻进系统 / Drilling system

凿岩机/Rock drill	2XHC95LMH / 22U
钎尾尺寸/Rod size	R38 / T38
冲击功率/Impact power	21KW / 22KW
频率/Impact Frequency	62Hz / 53Hz
孔径/Hole diameter	Φ42-102mm
推进梁翻转/Beam rotation	360°
推进梁补偿行程/Feed extension	1600mm
钻臂型号/Model of drill boom	K 40
钻臂形式/Form of drill boom	自动持平/Self-leveling
钻臂伸缩/Boom extension	1800mm